

**NOTE:**

1. LETTER ON COVER SHALL BE "S" WHEN USED IN SAN. SEWER SYSTEM AND "W" WHEN USED IN WATER SYSTEM.
2. RISER FOR VALVE BOX SHALL MATCH TYPE OF PIPE USED FOR MAIN.

**GENERAL SPECIFICATIONS**

1. CAST IRON SHALL BE 35,000 PSI
2. ASTM A48 CLASS 35B

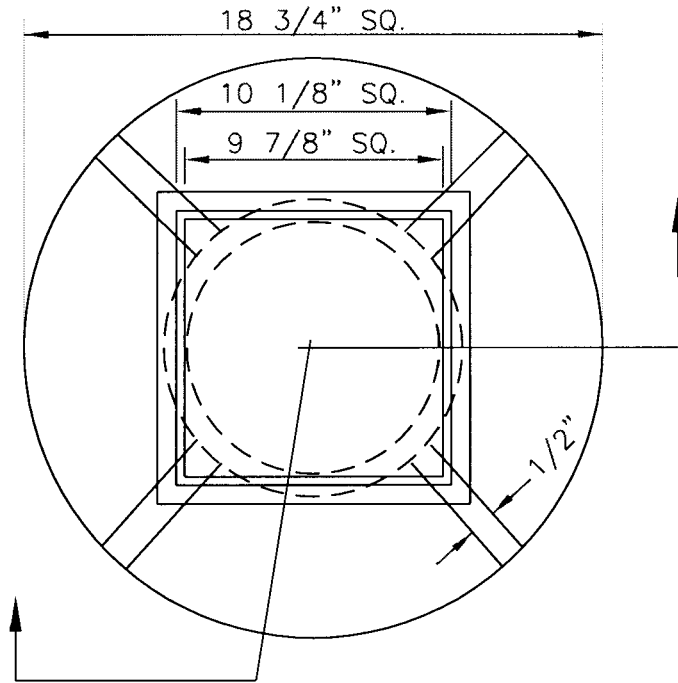

**PLAN VIEW**

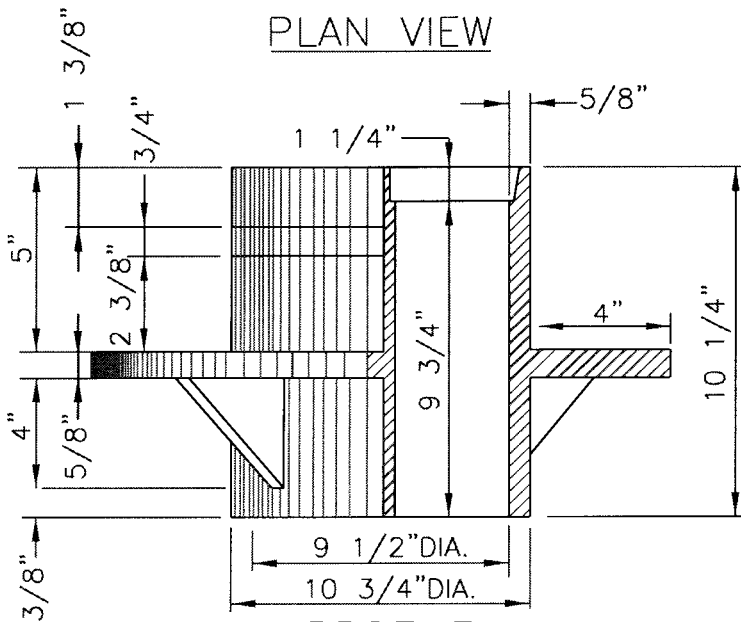

**PROFILE VALVE BOX**

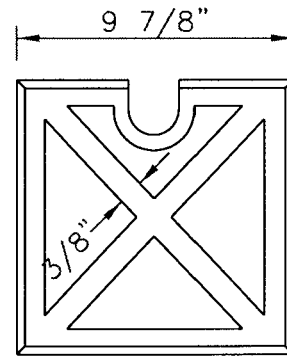
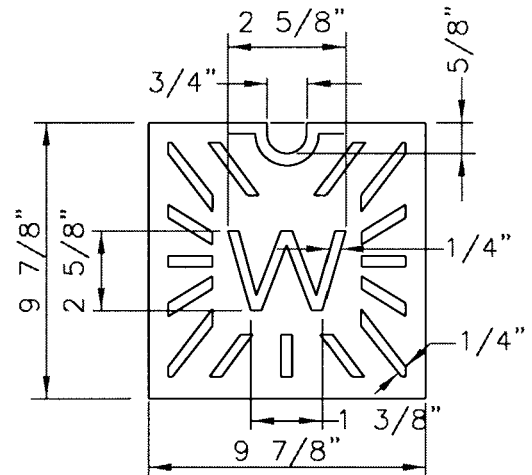

**PLAN VIEW VALVE LID**

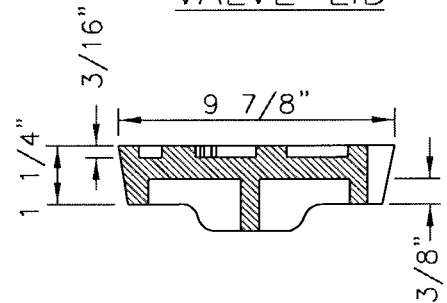

**PROFILE VALVE LID**

CITY OF NORFOLK – DEPARTMENT OF UTILITIES  
STANDARD DETAILS

SCALE:  
NOT TO SCALE

LARGE VALVE BOX  
FOR MAINS 8 INCHES AND LARGER

DRAWING NO.  
CWS 01

DATE: 03/07